

### Overview

ping20Si is a complete system designed to meet the conspicuity requirements for operating Unmanned Aircraft Systems (UAS) in controlled airspace. This system includes an integrated, high integrity Satellite Based Augmentation System (SBAS) Global Positioning Sensor (GPS) sensor derived from Technical Standard Order (TSO) C-199 Class B FYX technology, and a precision, temperature controlled, barometric sensor with accuracy beyond 60,000ft.



### Features

- Mode S transponder
- ADS-B 1090ES DF17 transmitter
- Integrated SBAS GPS
- Integrated static pressure sensor
- Meets the minimum performance requirements of the following RTCA specifications:
  - DO-181E Class 1, Level 2els @20W
  - DO-260B Class B1S @20W
- GPS/SBAS augmentation system. Receiver Autonomous Integrity Monitoring (RAIM) layer for Fault Detection and Exclusion (FDE)
- Temperature controlled static pressure sensor accurate to 60,000ft.
- Battery backed GPS for fast Time-to-First-Fix (TTFF)
- DO-160G environmental Cat B2
- Directly connects to PixHawk TELEM interface.
- GDL90 compatible CONTROL serial input. Compatible with popular autopilots.
- GDL90 ownership and altitude packets
- SMA 1030/1090MHz Antenna Connector
- Integrated GPS antenna
- U.S. Patents Pending

### Regulatory

Meets the requirements of:  
DO-181E Class 1, Level 2els (20W output power level)  
DO-260B Class B1S, DO-229D Class Beta 1, ICAO Annex 10, Volume IV, EuroCAE ED-115 Class LcF  
Radio Equipment directive: 2014 / 53 / EU

### Technical Specifications

Specification	Value
Input Power	11-28V 1W Ave On/Alt. 0.5W Standby
Size	50x25x17mm
Weight	20grams
SIL/SDA	1/1
Operating Temp	-45 to 80°C
Transponder	
MTL 1030MHz	-61dBm
Dynamic Range	-59 to 0dBm
1090 Transmit Power	20W Nominal
WAAS GPS	
Augmentation	SBAS
Sensitivity	-167dBm
Altimeter	
Range	-1000 to 60,000ft
Interfaces	
Control	
Control	57600bps GDL90, MavLink
Ownship	57600bps GDL90, MavLink
Programming	
Programming	115200bps GDL90
Options	
Wi-Fi Programmer Adapter	
1030/1090MHz Transponder Antenna	

## Electrical Specification

### Power Interface

Pin	Type	
1	Power	11-28V
2	Ground	

Mating Connector: Molex 0436450200  
Pins: 0462350001

### Control Interface

Pin	Type		
1	Input	RXD	GDL90, MavLink
2	Output	TXD	GDL90, MavLink
3	Power	5V	
4	Ground		

Mating Connector: JST ZHR-4  
Pins: SZH-002T-P0.5

### Programmer Interface

Pin	Type		
1	Input	NC	
2	Input	RXD	GDL90
3	Output	TXD	GDL90
4	Power	5V	Output
5	Ground	Ground	

Mating Connector: JST ZHR-5  
Pins: SZH-002T-P0.5

### Indicators

LED	ON	FLASHING
GREEN	Powered	Receiving Interrogation
RED	FAULT	Transmit

## Mechanical Specification

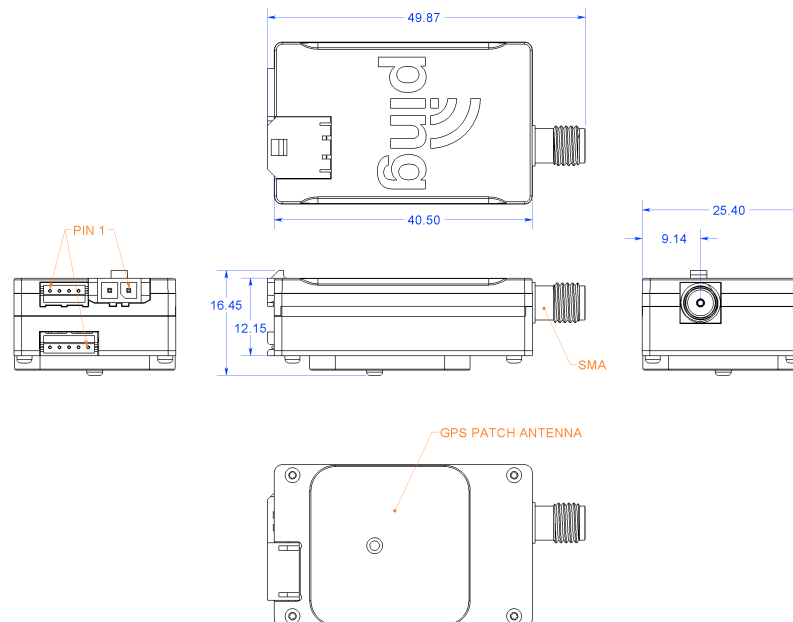

uAvionix reserves the right to alter product, services offerings, specifications, and pricing at any time without notice.

© Copyright 2020 uAvionix, all rights reserved. [www.uavionix.com](http://www.uavionix.com)