

FEATURES

- Pressure range up to $\pm 500\text{Pa}$ with high accuracy of $\pm 3.0\%$ m.v.
- Pressure based on thermal micro-flow measurement
- Outstanding hysteresis and repeatability
- Linearized and temperature compensated
- Digital I²C with 16bit resolution
- Cost Effective
- RoHS and REACH compliant
- Digital I2C Output
- Detects pressure difference as low as 0.016 Pascal



APPLICATIONS

- Medical CPAP and Ventilator
- HAVC and building control solution
- Burner Control
- Filter Monitoring
- Process Control and Automation



DESCRIPTION

ACEINNA's MDP200 series MEMS differential pressure sensors measure ultra-low gas pressures covering the range of up to $\pm 500\text{Pa}$ ($\pm 2\text{ inH}_2\text{O}$). The technology is based on ACEINNA's highly successful proprietary CMOS thermal accelerometers already sold in millions. ACEINNA's thermal flow sensing element is monolithically integrated with CMOS signal processing circuitry and embedded software capable of converting gas flow rates to a digital format. The signal is linearized and temperature compensated. MDP200 series offers incredible sensitivity detecting pressure down below 0.016 Pascal. Other features include wide dynamic range, superb long-term stability, and outstanding repeatability and hysteresis.

1. Performance¹

Parameter	-500 Pa
Measurement Range	±500Pa
Zero-point Accuracy ²	±0.03 Pa
Span Accuracy ²	± 3.0% m.v
Total Error (0°C - 50°C)	±3.5% m.v
Zero-point Repeatability and Hysteresis ²	±0.03 Pa
Resolution (Near Zero)/Lowest Detectible Pressure ⁴	0.016 Pa
Response Time/Communication Update Rate	≤8ms
Span Repeatability and Hysteresis ³	0.5% m.v.
Over Pressure	1.5Bar
Span Shift due to Temperature Variation	0.05 %m.v. per °C
Offset Shift due to Temperature Variation	<0.03Pa
Offset Stability	<TBD
Non-Linearity(BFSL)	0.3%FS (0-100 Pa) 0.4%FS (0-200 Pa) 0.8%FS(0-500 Pa)
Orientation Sensitivity	< resolution - port @ 90° vs. 270° <0.05 Pa – port @ 90° vs. 180°
Gas Flow Through Sensor ³	100 ml/min @ 500 Pa

1. All sensor specifications are valid with air as medium at 21°C temperatures with 1 standard atmospheric pressure (101325Pa), 50% RH, and a 3.3V DC power supply, unless otherwise specified. Customized versions are available, please contact factory for calibration under other conditions of pressure ranges, temperatures, and gases

2. Accuracy specifications apply over operating conditions. With 16-bit resolution, this accuracy represents the total of non-linearity, hysteresis, zero and span shift, repeatability and temperature effects.

3. MDP200 operates based on thermal mass flow principle. Gas flow is required to measure the pressure difference.

4. Lowest detectable pressure is an output average of at least 10 consecutive readings above zero.

2. Environment

Parameter	-500 Pa
Operating Temperature	-20°C to +80°C
Storage Temperature	-40°C to +85°C
Relative Humidity (Non-Condensing)	To 95%
Radiated Susceptibility	5 V/m
ESD	4/(8) kV
Shock	50G @ 5 ms, G _{Peak}
Vibration (5-2000 Hz)	20, G _{rms}
Media Compatibility	N ₂ , O ₂ , Air
Orientation Sensitivity	TBD
Protection	IEC IP30
Barb Strength	4, lbf (3 orthogonal directions)

3. Electrical

Parameter	-500 Pa
Input Voltage Range	3.0-3.6 Vdc
Supply Current	7 mA
Interface	I ² C
Resolution	16 Bit (bi-direction)
Bus Clock Frequency	< 400 KHz
I2C Default Address	0x31

4. Material

Parameter	Description
Wetted Material	FR4, Silicon Nitride, Silicon Oxide, Silicon, Epoxy, Lead-free solder, PBT (polybutylene terephthalate)
Standard Compliant	RoHS and REACH

5. I²C Interface

5.1. Pinout Configuration

Pin	Name	Description
1	SCL	Serial Clock Line for I ² C bus
2	VDD	Power Supply
3	GND	Ground
4	SDA	Serial Data Line for I ² C bus

5.2. Mating Connector

Recommended mating connector: Molex DuraClick™ Series 5023510400

5.3. External Interface

SCL and SDA line must be connected to VDD with about 4.7k Ohm pull-up resistor in series, the range of VDD is 2.7-5.5V. Calibration of the MDP200 is performed at a voltage of 3.3V.

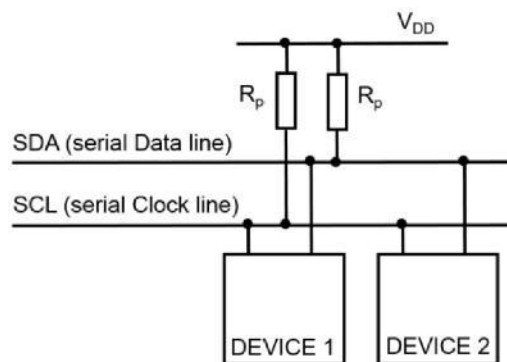

5.4. Address

The I²C address is 7 bits long, followed by a write bit (0) or a read bit (1).

5.5. Communication

MDP200's communication interface is Phillips I²C compatible as shown below, the recommended frequency of SCL line is approximately 100kHz.

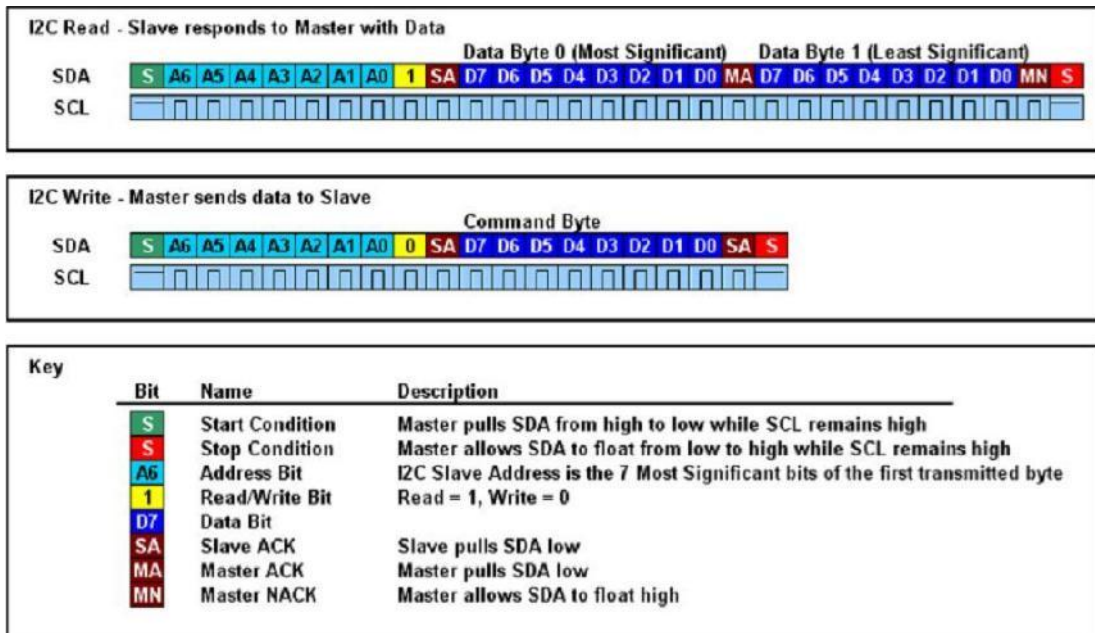

5.6. Trigger measurement operation

MDP200 works in slave mode, it has 7-bit slave address, by default, the slave address is 0x31, the following bit is either write bit(0) or read bit(1).

To trigger measurement operation, the master must write a command 0xC1 into sensor to start the measurement, then wait for 15ms, the master can read out 2 bytes differential pressure data from the register 0 followed by 1 byte CRC code. To read the differential pressure data, the first byte transmitted must be 0x63 which indicates that master will read from sensor whose slave address is 0x31. Immediately with master generating pulses of 3 bytes, the master can read out the 2 bytes data and 1 byte CRC code.

For example, the slave address is 0x31, the master trigger the measurement first, then read out the data in register 0, there are 3 steps as the following:

- (1) Master write into sensor the trigger command 0xC1.

Slave address + write bit	Measurement trigger command
0x62	0xC1

(2) Wait at least 15ms, master should write into slave the register address 0x00, which specify that master will read data from register 0 of slave.

Slave address + write bit	Register address
0x62	0x00

(3) Master reads differential data

Slave address + read bit	16 SCL pulses
0x63	High Byte, Low Byte, CRC Code

Once slave receive the slave address and the read bit (0x63) from master, slave will return the 2 bytes data showed in the table below.

High Byte	Low Byte	CRC Code

With the pulses of 3 bytes is being generated by master, slave will return the 2 bytes differential pressure data and 1 byte CRC code.

Notes:

- Slave returns the high byte first, then the low byte, and at last the CRC code
- Recommend that each trigger measurement command should be sent after data reading is completed.

5.7. Data Format

The output data from slave's register 0 is 2 bytes signed integer data. If the data is divided by 64, the result will be the differential pressure which is from -510 to 510 Pa.

5.8. Reset Command

MDP200's circuit can be reset to initial status by writing reset command 0xFE into device.

Note:

The device will not work normally until 2 seconds after writing reset command. So, do not write any data into device in 2 seconds after writing reset command, or there will be unpredictable error.

5.9. CRC-8 Redundant Data Transmission

MDP200 use cyclic redundancy checking (CRC) technique for error detection in I2C Transmission. The master appends an 8-bit checksum to the actual data sequence. The checksum holds redundant information about the data sequence

and allows the receiver to detect transmission errors. The computed checksum can be regarded as the remainder of a polynomial division, where the dividend is the binary polynomial defined by the data sequence and the divisor is a “generator polynomial”. The MDP200 implements the CRC-8 standard based on the generator polynomial $x^8 + x^5 + x^4 + 1$.

Note:

CRC here is only used for data transmitted from the slave to the master. For details regarding cyclic redundancy checking, please refer to the relevant literature.

In the master’s program, must use the 2 bytes differential pressure read out from MDP200’s register 0 and polynomial $x^8 + x^5 + x^4 + 1$ to calculate out one byte result data, then compare the result data calculated by master and the CRC code from MDP200. If they are not equal, it indicates that there is error in I2C communication, the master must discard the measurement data that time, and trigger the measurement again, then read from MDP200’s register 0 again until the result data and the CRC code are equal.

6. Altitude Correction

The MDP200 series utilizes a thermal principal to measure pressure difference to achieve high sensitivity, robustness and stability. Changes in altitude from the calibration condition (sea level) require output adjustment as shown below:

Air pressure above sea level can be calculated as:

$$p = 101325(1 - 2.25577 * 10^{-5} h)^{5.25588}$$

Where

p is air pressure (Pa)

h is altitude above sea level (m)

Altitude (meters)	Correction Factor
0	1.00
250	1.03
425	1.05
500	1.06
750	1.09
1000	1.13
1500	1.20
2000	1.27
3000	1.44

7. Effects on Hose Lengths

Since the MDP200 series utilizes a thermal measurement principal with air flowing through the sensor, long tubing length has an impact to the sensor output due to frictional losses. The amount of impact depends on the hose material, internal diameter and total length leading to and away from the sensor. In general, tubing length shorter than 1 meter has less 1% (m.v.) impact. Refer to application notes on tubing length effect of MDP200 series for details.

8. Mechanical Specifications

MANIFOLD MOUNT VERSION

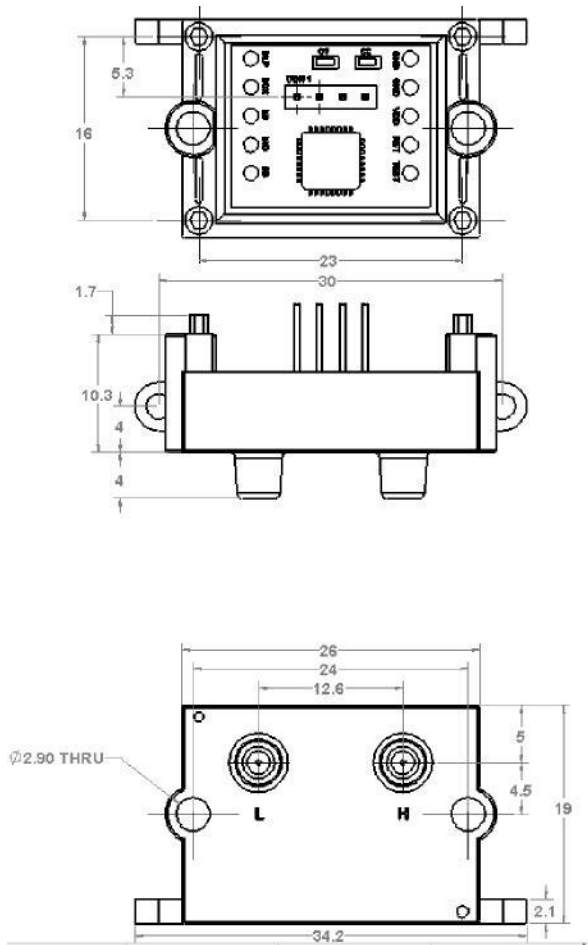

BARB FITTING VERSION

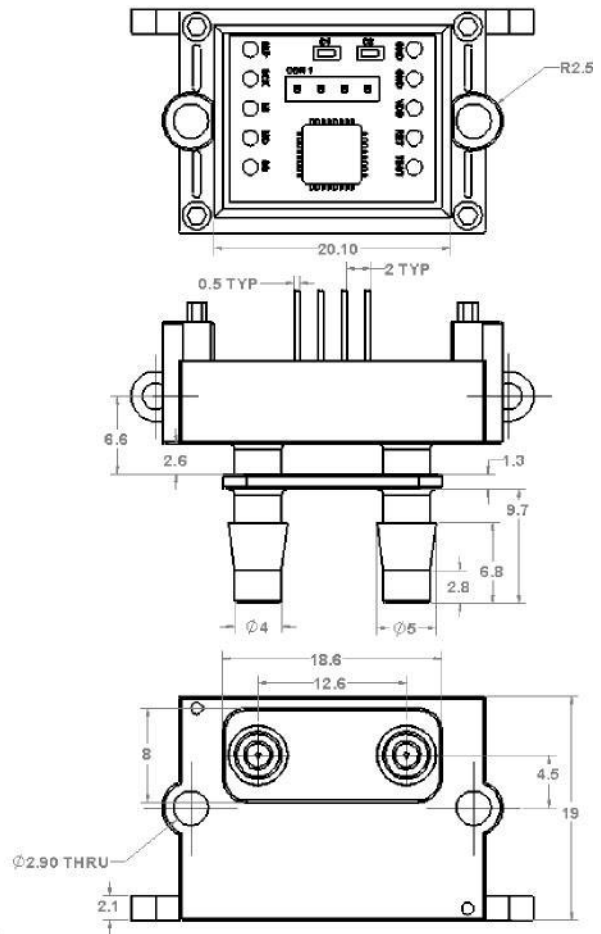

9. Foot Print

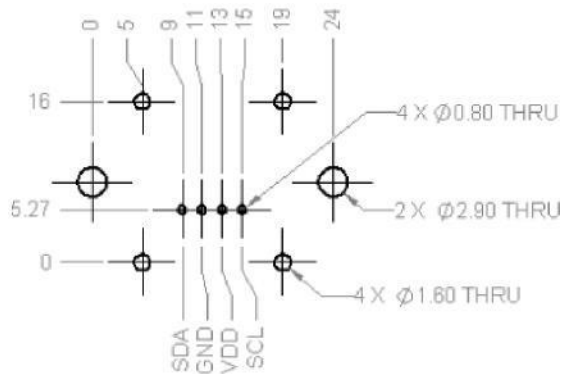

10. Ordering Information

Options	Ranges		Calibration		Housing	
MDP200	-500	500Pa	B U	Bi-Directional Uni-Directional	T Y	Manifold Barb

Example: MDP200-500BY = MDP200 differential pressure sensor, 500 Pascal, Bi-Directional, Barb Fitting

11. Revision History

Date	Author	Version	Changes
June 2017	O. Silpachai	1.0	Initial Release
July 2017	J. Pern	1.1	Revised Zero-Point Accuracy and Repeatability. Improvement of Null DP test setup (H and L ports common) Revised lowest detectable pressure based on averaging