

### Product Description

The BFM4120 is a compact, multi-function Front-End RFIC (Radio Frequency Integrated Circuit) intended for 802.15.4 ZigBee™/ Thread, Bluetooth® Smart, and proprietary ISM wireless protocol systems in the 2.4GHz band.

The BFM4120 is optimized for battery operation with enhanced efficiency, operating over a wide voltage supply range from 1.8V to 3.6V, suited for a wide array of applications including battery-powered wireless systems.

The BFM4120 combines a transmit power amplifier (PA), receive low noise amplifier (LNA), a single pole, double throw (SPDT) transmit / receive (T/R) switch, and an SPDT antenna switch (Figure 1) in a 3.0 x 3.0 x 0.55mm 16-pin QFN package. It also comes integrated with filter networks and input/output matching circuitry. The device delivers up to +21dBm saturated output power at a supply voltage of 3.3V.

### Applications

- IoT (Internet of Things) / M2M Connectivity
- 802.15.4 Zigbee, RF4CE, Proprietary ISM
- Bluetooth® Low Energy (BLE) Mesh Networks
- Smart Home Hubs and Gateways
- Consumer Electronics, Smart Appliances
- Smart Lighting, Smart Metering
- Drone, Toy, Media Remote Controller
- Industrial Wireless Sensor Networks
- Home, Industrial, Factory Automation
- Wireless Sensor Nodes & Networks
- Wireless Audio & Video

### Package Type



16-Lead 3 x 3 x 0.55mm, QFN Package

**Figure 1: Package Type**

### Device Features

- 2.4 – 2.5 GHz Frequency Range
- High Efficiency Optimized for Battery Operation
- Delivers up to +21dBm Output Power at 3.3V
- 75mA at +20dBm Output Power at 3.3 V
- 2.6dB LNA Noise Figure
- 1.8 – 3.6V Operation
- Single-Ended Transceiver Interface
- -40°C to 125°C Extended Temperature Range
- 3.0 x 3.0 x 0.55 mm 16-Pin QFN Package

### Block Diagram

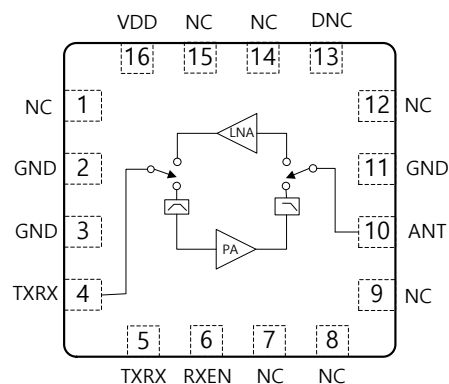

**Figure 2: Functional Block Diagram**

**Table 1: BFM4120 Pin Signal Description**

Pin	Name	Description	Pin	Name	Description
1	NC	Not connected internally	9	NC	Not connected internally
2	GND	Ground	10	ANT	Antenna Port (DC shorted to GND)
3	GND	Ground	11	GND	Ground
4	TXRX	Transmit/Receive Port (DC shorted to GND)	12	NC	Not connected internally
5	TXEN	Control Logic Pin	13	DNC	Do Not Connect
6	RXEN	Control Logic Pin	14	NC	Not connected internally
7	NC	Not connected internally	15	NC	Not connected internally
8	NC	Not connected internally	16	VDD	DC Voltage Supply

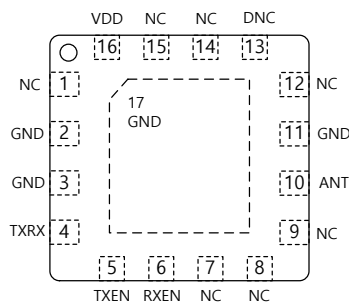

**Figure 3 :Pin Description (Top View)**

### General Specifications

**Table 2: BFM4120 Absolute Maximum Ratings**

Parameter	Units	Minimum	Maximum
Supply Voltage (VDD)	V	0	3.7
Control Logic Pin (TXEN, RXEN)	V	0	VDD
Transmit Output Power at ANT Port	dBm		23
Transmit Input Power at TXRX Port	dBm		10
Receive Input power at ANT Port	dBm		5
Storage Temperature	°C	-40	150

Note: Sustained operation at or above the Absolute Maximum Ratings for any single or combinations of the parameters above may result in permanent damage to the device and is not recommended. All Maximum RF Input Power Ratings assume 50-Ohm terminal impedance.

### ESD Handling Information

Electro Static Discharge (ESD) can cause immediate (or latent) failures in semiconductor Integrated Circuits (ICs). BeRex, Inc. RFIC products are designed with integral ESD protection structures, and all IC products are tested to meet industry standards for ESD event survival. Users must adhere to all precautions for handling ESD sensitive devices throughout the manufacturing, test, shipping, handling, or operational processes, and during field service operations in order to achieve optimum system performance and life expectancy. Production quantities of this product are shipped in a standard tape and reel format. The ESD rating for BFM4120 on HBM mode is 1000V.

**Table 3: BFM4120 Recommended Operating Conditions**

Parameter	Units	Minimum	Typical	Maximum
Supply Voltage (VDD, recommended)	V	2.7	3.3	3.6
Supply Voltage (VDD, extend supply voltage)**	V	1.8**		3.6
Control Pin - Logic High State (TXEN, RXEN)	V	1.2		VDD*
Control Pin - Logic Low State (TXEN, RXEN)	V	0		0.4
Operating Frequency Range	GHz	2.4		2.5
Operating Temperature	°C	-40	+25	+125

\*For Control Voltages > 3.0V, a 10KΩ series resistor should be used at the Control Logic Pins.

\*\*Functional working with degraded performance for the supply voltage range 1.8V to 2.7V.

**Table 4: BFM4120 Transmit Electrical Specifications**

(VDD = 3.3V, T<sub>Ambient</sub> = 25°C, Unless Otherwise Noted)

Parameter	Units	Min	Typ	Max	Test Conditions
Frequency Range	GHz	2.4		2.5	
Saturated Output Power	dBm		21		
Large-Signal Gain	dB		24		At +20dBm
Current Consumption	mA		75		At +20dBm at ANT pin
			90		At +21dBm at ANT pin
Tx Quiescent Current	mA		15		
Second Harmonic	dBm/MHz		-50		Up to +21dBm with Harmonic Filter as specified
Third Harmonic	dBm/MHz		-50		
Input Return Loss	dB		-10		
Isolation	dB		24		In Shutdown Mode TXRX pin to ANT pin
Load VSWR for Stability			6:1		All Non-harmonic Spurs Less than -43dBm/MHz Up to +21dBm
Load VSWR for Ruggedness			10:1		No Damage

**Table 5: BFM4120 Receive Electrical Specifications**

(VDD = 3.3V, T<sub>Ambient</sub> = 25°C, Unless Otherwise Noted)

Parameter	Units	Min	Typ	Max	Test Conditions
Frequency Range	GHz	2.4		2.5	
Small-Signal Gain	dB		11.5		
Current Consumption	mA		8		
Noise Figure	dB		2.6		
Input P1dB	dBm		-8		
Input IP3	dBm		0		
Input Return Loss	dB		-8		
Output Return Loss	dB		-8		

**Table 6: BFM4120 Shutdown Mode Specification**

(VDD = 3.3V, T<sub>Ambient</sub> = 25°C, Unless Otherwise Noted)

Parameter	Units	Min	Typ	Max	Test Conditions
Shutdown Current	uA		0.15		
Shutdown Mode ANT-TXRX Isolation	dB		23		

**Table 7: BFM4120 Shutdown Mode Specification**

(VDD = 3.3V, T<sub>Ambient</sub> = 25°C, Unless Otherwise Noted)

Parameter	Units	Min	Typ	Max	Test Conditions
TX to RX	µsec		0.7		From 50% of RXEN to 90% of RX powe
TX to Shutdown	µsec		0.25		From 50% of TXEN to 10% RF
RX to TX	µsec		0.3		From 50% of TXEN to 90% RF
RX to Shutdown	µsec		0.15		From 50% of RXEN to 10% RF
Shutdown to TX	µsec		0.5		From 50% of TXEN to 90% RF
Shutdown to RX	µsec		0.85		From 50% of RXEN to 90% RF

**Table 8: BFM4120 Control Logic**

"1" = Logic High, "0" = Logic Low

TXEN	RXEN	Operational Mode
0	0	Shutdown Mode
0	1	RX Mode
1	0	TX Mode
1	1	TX Mode

### Application Notes

The BFM4120 Application note provides detailed descriptions and test data over various operating conditions. Visit [www.BeRex.com](http://www.BeRex.com) or contact BeRex at [sales@BeRex.com](mailto:sales@BeRex.com) to request additional documentation.

### Application Schematic and PCB Layout

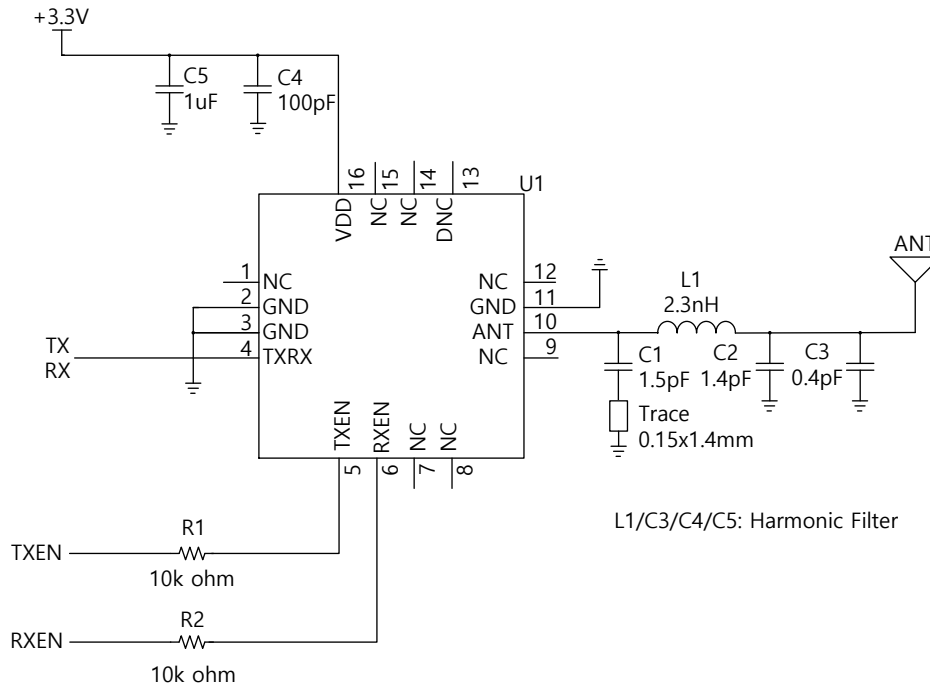

**Figure 4 : Evaluation Board Schematic**

**Table 9: Bill-of-Material (BOM)**

Component#	Component Value	Manufacturer's P/N	Manufacturer's Name
C5	1 uF 0402		Murata
C4	100pF 0201		Murata
C1	1.5pF 0201	GRM0335C1E1R5BA01D	Murata
C2	1.4pF 0201	GRM0335C1H1R4BA01D	Murata
C3	0.4pF 0201	GRM0335C1HR40WA01E	Murata
L1	2.3nH 0201	LQP03TN2N3B02D	Murata
R1, R2	10kohm 0201	ERJ-1GEJ103C	Panasonic
U1		BFM4120	BeRex

### Application Schematic and PCB Layout

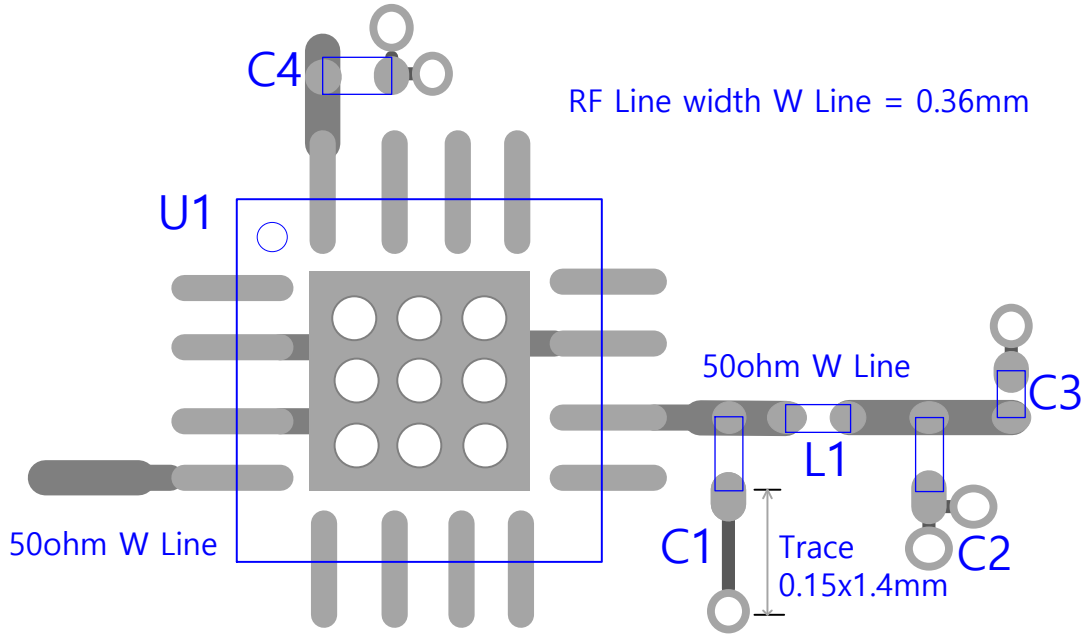

Figure 5: Reference Design Schematic and PCB Layout

Soldermask (0.01mm)	FINISH THICKNESS : 1.6T
Cu 0.5 Oz + PLATING (0.035mm) Top Layer	
PREPREG (0.19mm) / Er = 3.9	
Copper 1 Oz (0.035mm), Inner1 Layer	
CORE (1.06mm) / Er = 3.9	
Copper 1 Oz (0.035mm), Inner2 Layer	
PREPREG (0.19mm) / Er = 3.9	
Cu 0.5 Oz + PLATING (0.035mm) Top Layer	
Soldermask (0.01mm)	

Figure 6: Evaluation Board PCB Layer Information

Preliminary Datasheet

### Package Dimensions

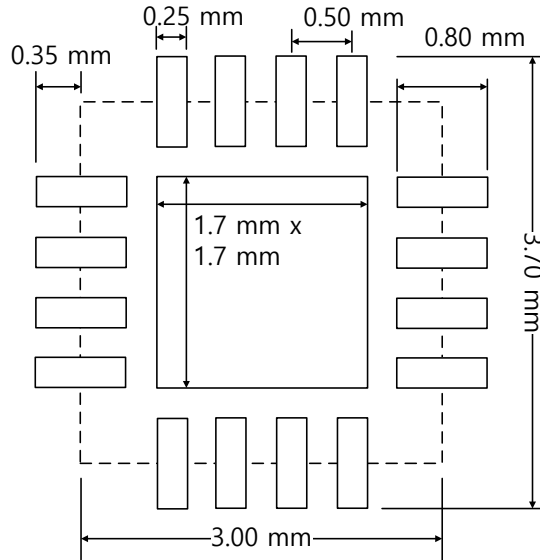

Figure 7: BFM4120 Recommended PCB Layout Footprint

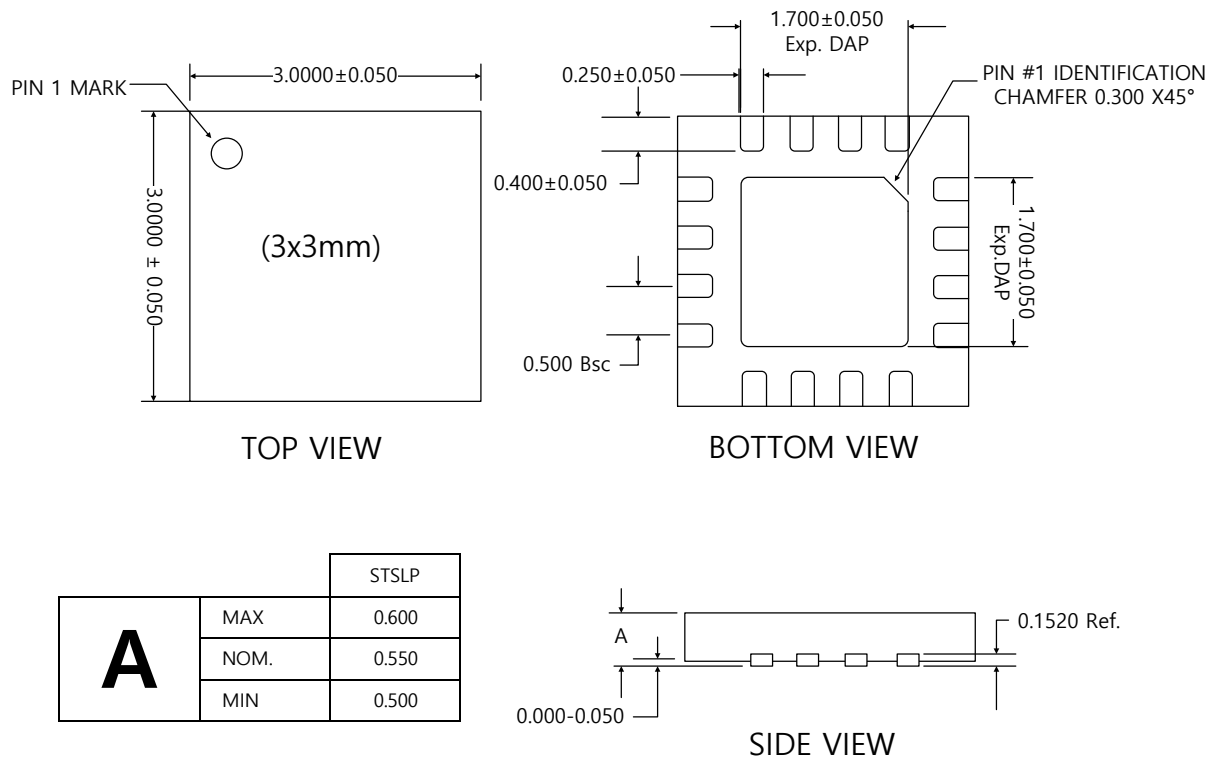

Figure 8: BFM4120 Package Dimension

<b>A</b>		STSLP
	MAX	0.600
	NOM.	0.550
	MIN	0.500

Preliminary Datasheet

### Tape & Reel

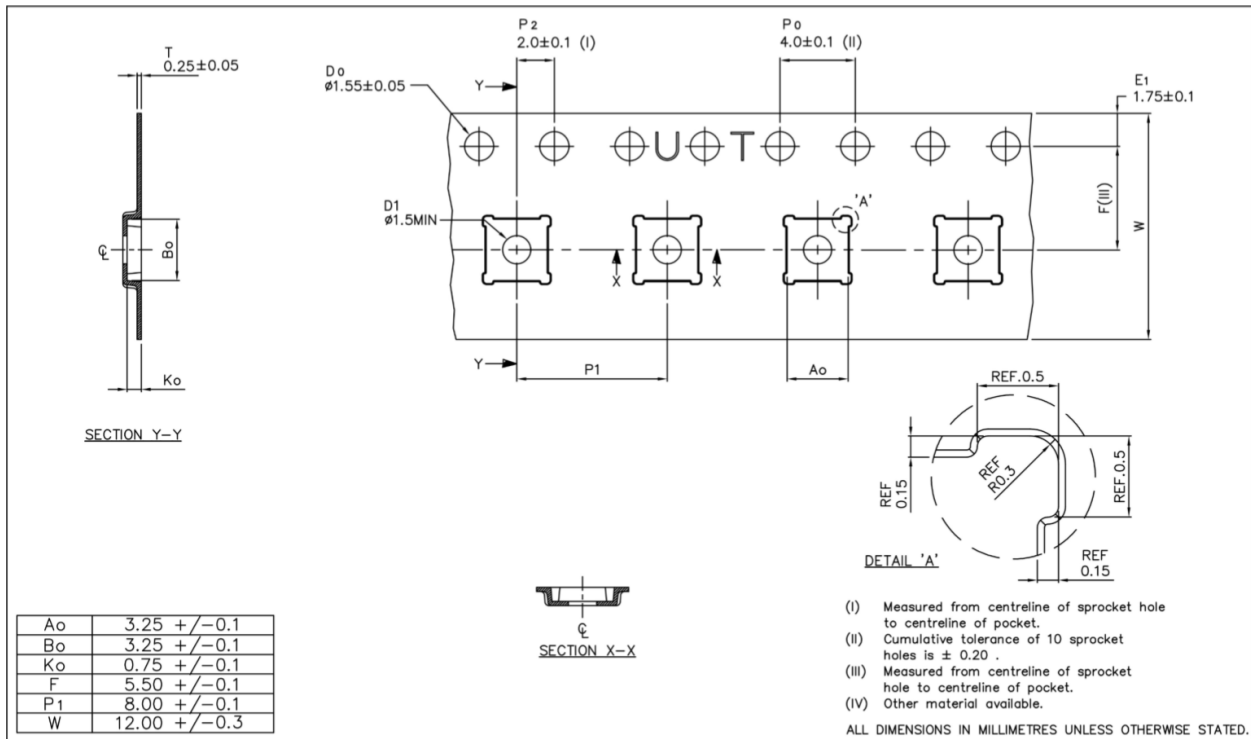

Figure 9: Tape & Reel

#### Packaging information :

Tape Width (mm) : 12

Reel Size (inches) : 7

Device Cavity Pitch (mm) : 8

Device Per Reel : 1000EA

### Package Marking



BF4120 : BFM4120

YY=Year

WW=Work Week

XX=Lot Number

Figure 10: Package Marking



### Lead plating finish

#### 100% Tin Matte finish

(All BeRex products undergoes a 1 hour, 150 degree C, Anneal bake to eliminate thin whisker growth concerns.)

### MSL / ESD Rating

ESD Rating : Class 1C  
 Value : Passes < 2000V  
 Test : Human Body Model (HBM)  
 Standard : JEDEC Standard JESD22-A114B

MSL Rating : MSL1 at +265°C convection reflow  
 Standard : JEDEC Standard J-STD-020



Proper ESD procedures should be followed when handling the device.

### NATO CAGE code:

2	N	9	6	F
---	---	---	---	---

Preliminary Datasheet