

KEY FEATURES

Support for GPS L1, GLONASS L1, Galileo E1 and BeiDou B1

Low-profile Fuselage/Bulkhead Mounting

Sub-centimeter phase center repeatability

Small rugged package ideal for vehicle or man portable applications



TRIMBLE AV33 GNSS ANTENNA

HIGH PERFORMANCE GNSS SUPPORT

The Trimble AV33 GNSS Antenna has been designed to support high accuracy aerial, land and marine applications in one compact design. The rugged 4 hole bulkhead mounting allows the antenna to be used in the most rugged of environments.

COMPREHENSIVE GNSS SUPPORT

The Trimble AV33 GNSS antenna offers support for present and future L1 GNSS signals, including GPS, GLONASS, Galileo and BeiDou. This ensures that the antenna will operate with your present and most likely future GNSS receivers.

ROBUST, LOW-MULTIPATH GPS ANTENNA

The antenna resists unwanted signal interference or multipath, which can cause inaccurate measurements. Multipath is caused by signals being reflected from surfaces such as the ground, surrounding trees, or buildings.

FLEXIBILITY

The antenna is an aviation type of design. The bulkhead mounting ensures only the rugged radome is exposed to the elements. This is an ideal design for customers building machine control systems. The antenna can be mounted flush with the vehicle surface or on the top of a pole mount. The TNC connector is located on the underside of the unit ensuring the attached cable is also protected from the environment.

TRIMBLE AV33 GNSS ANTENNA

PERFORMANCE

- L1 Band GNSS Frequency tracking Including:
 - GPS: L1
 - GLONASS: L1
 - Galileo: E1
 - BeiDou: B1
 - SBAS: WAAS, EGNOS, QZSS, Gagan, MSAS
- Quality signal tracking
- TNC female signal connector
- Small cross-sectional area to reduce wind loading
- Low voltage, low power consumption
- Integral low noise amplifier
- Powered by GNSS receiver via coaxial cable
- High gain for reliable tracking in difficult environments
- 4 recessed bulkhead mounting holes
- Rugged radome designed for machine environments

ELECTRICAL

Frequencies 1551–1615 MHz
 Signal gain 43 dB
 Voltage 4.5 V DC to 18 V DC
 Polarization Right Hand Circular
 Axial Ratio 3 dB Max @ boresight
 Amplifier Noise Figure : 2.5 dB Max
 Impedance : 50 Ohms
 VSWR : ≤ 2.0:1

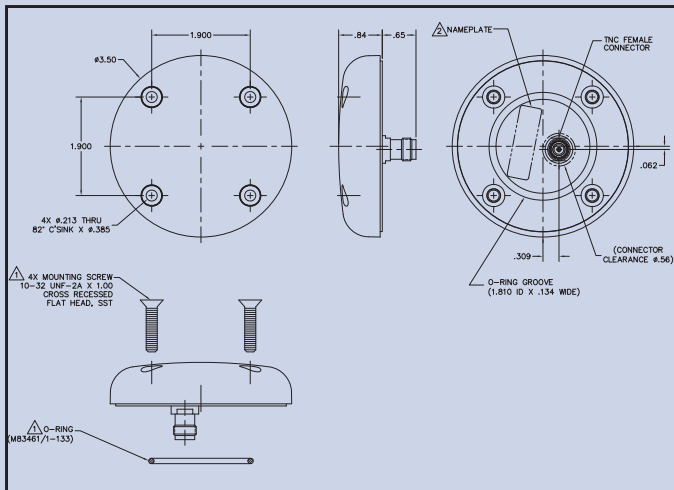

HARDWARE

Dimensions 8.9 cm diameter, 2.1 cm height (3.5" diameter, 0.84" height)
 Weight 0.200 Kg (0.44 lb)
 Operating Temperature -55 °C to +85 °C (-67 °F to +185 °F)
 Altitude ≤16,764 m (55,000 ft)
 Finish UV resistant, high impact thermoplastic white radome with aluminum base
 Compliance ROHS

ENVIRONMENTAL QUALIFICATIONS

CONDITIONS	DO-160D SECTION	STRING CATEGORY	DESCRIPTION
Temperature Variation	5	A	-55 °C to +85 °C, 10°/min, 2 cycles
Humidity	-	Method 507.4	MIL-STD-810-F
Shock	-	Method 516.5	MIL-STD-818-F Procedure II
Vibration	-	Method 516.5C-3	MIL-STD-810-F, Section 514.5 CVII



Antenna shown with optional bracket. Bracket allows for mounting on single center 5/8 bolt or four perimeter bolts.



03-9243358 :פקס ▪ 03-9243352 :טל ▪ 7042 פ"ת ▪ ת.ד. 14, אודם 14, ת.י. 7042
www.hypertech.co.il ▪ sales@hypertech.co.il

Specifications subject to change without notice.

© 2014, Trimble Navigation Limited. All rights reserved. Trimble and the Globe & Triangle logo are trademarks of Trimble Navigation Limited, registered in the United States and in other countries. Maxwell is a trademark of Trimble Navigation Limited. All other trademarks are the property of their respective owners. 11/2014

AMERICAS
 TRIMBLE NAVIGATION LIMITED
 Integrated Technologies
 510 DeGuigne Drive
 Sunnyvale, CA 94085 USA
 +1-408-481-8000 Phone
 Email: americasales-intech@trimble.com

EUROPE & MIDDLE EAST
 TRIMBLE NAVIGATION LIMITED
 Integrated Technologies
 Germany
 +49 (6142) 2100-348 Phone
 France
 +33 2 28 09 3800 Phone
 Email: emeasales-intech@trimble.com

CHINA
 TRIMBLE NAVIGATION LIMITED
 Integrated Technologies
 Email: chinasales-intech@trimble.com

ASIA - PACIFIC
 TRIMBLE NAVIGATION LIMITED
 Integrated Technologies
 Email: asiasales-intech@trimble.com

RUSSIA
 TRIMBLE NAVIGATION LIMITED
 Integrated Technologies
 +49 (6142) 2100-348 Phone
 Email: rusesales-intech@trimble.com