

REVISIONS			
SYM	DESCRIPTION	DATE	APPROVED
D	UPDATED PER ECO 9600 & 9607	03/03/11	
ADDED ETSO C190			

NOTES: UNLESS OTHERWISE SPECIFIED.

1. MOUNTING SCREWS AND O-RING SUPPLIED BY AEROANTENNA.
2. LABEL SIZE, SHAPE, CONTENTS AND LOCATION ARE SUBJECT TO CHANGE WITHOUT NOTICE.
3. TOLERANCE: .XX = ±.03
.XXX = ±.010

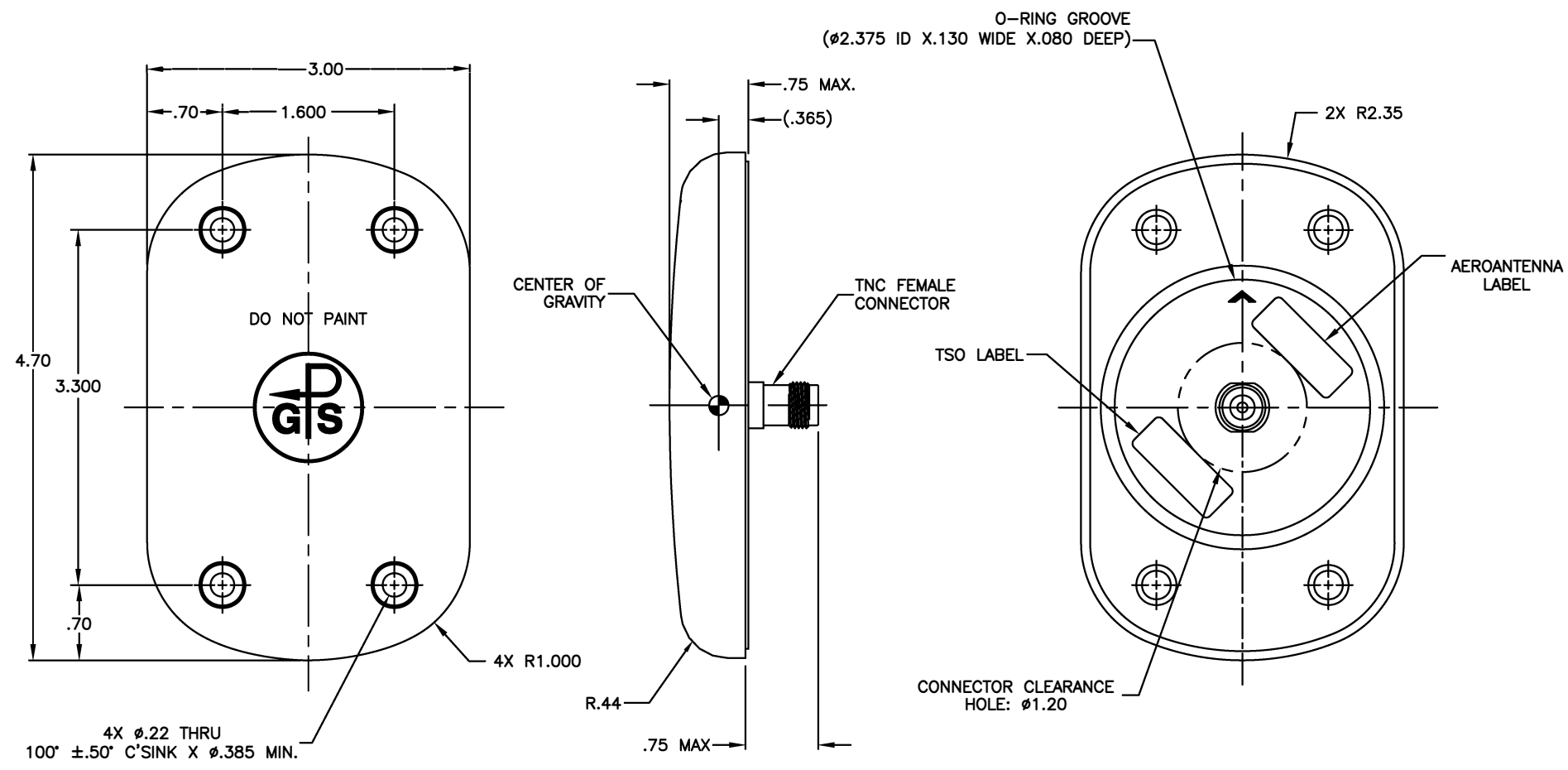

SPECIFICATION:

FREQUENCY: 1575.42 ±10.23 MHz
 POLARIZATION: RIGHT HAND CIRCULAR
 AXIAL RATIO: 3 dB MAX. AT BORE SIGHT
 RELATIVE RADIATION COVERAGE: PER DO-301

AMPLIFIER:
 GAIN: SPECIFY, MIN. GAIN 29.5 dB REQUIRED
 NOISE FIGURE: 2.5 dB MAX. @25°C
 IMPEDANCE: 50 OHMS
 VSWR: ≤1.5:1
 POWER HANDLING: 1 WATT

FINISH: WEATHERABLE POLYMER
 CONNECTOR: TNC F
 WEIGHT: 8 OZ MAX.
 ALTITUDE: 55,000'
 OPERATING TEMP: -55°C TO +70°C
 STORAGE TEMP: -55°C TO +85°C
 DESIGNED TO: DO-160E, ENV CAT: F2-AB[BD][S(CLMY)U(FF1)]X[SY]FSXSZXXX[ZCZW]YH[A4J44][2A]CAC ARINC 743, RTCA/DO-301

TSO: C190
 ETSO: C190



PART NO. DESIGNATION:
 AT575-343XXX-XXXX-XXX-XX-XX-XX

CUSTOMER ID (IF APPLICABLE)
 COLOR: W = WHITE, B = BLACK, S = SMOKE GRAY
 CONNECTOR: TNC F = TNC FEMALE
 CABLE LENGTH: *000 = IN INCHES

MAGNET: NM = NO MAGNET
 GAIN (± 3 dB): 33 = 33 dB (60 mA max)
 VOLTAGE: RG = 4.5 - 15 VDC

* = OPTION NOT AVAILABLE WITH THIS MODEL
 STANDARD MODEL = AT575-343W-TNCF-000-RG-33-NM



03-9243358 :פקס ▪ 03-9243352 :טל ▪ ת.ד. 7042 פ"ת ▪ 14 אודם ת.י.
 www.hypertek.co.il ▪ sales@hypertek.co.il

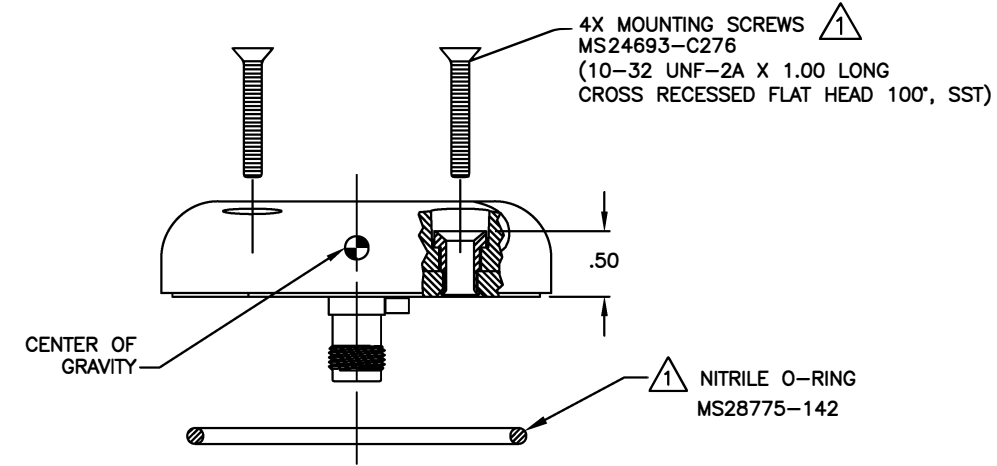

DO NOT SCALE THIS DRAWING	DRAWN	J. GUTIERREZ	08/23/07
REMOVE BURRS AND BREAK SHARP EDGES:	CHECKED	B. DANZER	09/19/07
PART TO BE CLEAN AND OIL FREE	ENGR	K. RERKSAWAT	09/18/07
ALL DIMENSIONS ARE IN INCHES	MFG	D. LEVY	09/18/07
DIMENSIONING & TOLERANCING PER ASME Y14.5M-1994	Q.A.	B. RUBENI	09/18/07
TOLERANCES:	APPROVED	G. SHAR	09/18/07
XXX ±.01 FRACT = ±1/32	DRAWN IN	CAD	
XXX ±.005 ANG. = ±1/2°			
✓ SURFACE ROUGHNESS MACHINED PARTS V63 MOLDED PARTS V32			
HOLE DIA. TOLERANCE			
.0135 - .125 +.001/-0.001			
.126 - .250 +.005/-0.001			
.251 - .500 +.008/-0.001			
.501 - .750 +.008/-0.001			

AeroAntenna Technology Inc
 AS9100 CERTIFIED CO.

TITLE: GPS ANTENNA

SIZE: B CAGE CODE: OUVG2 DRAWING NO.: AT575-343 REV: D

SCALE: NONE I:\CAD\AT575\343\AT575-343_D SHEET 1 OF 1

PROPRIETARY NOTE: This document contains information of AeroAntenna Technology Inc. (AAT). Neither the document nor said proprietary information shall be published, reproduced, copied, disclosed or used for any other purpose other than consideration of document without the express written permission of a duly authorized representative of said AeroAntenna Technology Inc.