

PROPRIETARY NOTICE: This document contains proprietary information of AAT Inc. neither the document nor said proprietary information shall be published, reproduced, copied, disclosed or used for any purpose other than consideration of this document without the express written permission of a duly authorized representative of said Company.

REVISIONS			
SYM	DESCRIPTION	DATE	APPROVED
A	PRODUCTION RELEASE SEE ECO 4555	08/21/00	

NOTES: UNLESS OTHERWISE SPECIFIED.

- 1 LOGO OPTIONAL.
- 2 LABEL SIZE, SHAPE AND CONTENTS SUBJECT TO CHANGE WITHOUT NOTICE.
- 3 ASSEMBLE ANTENNA TO ADAPTER USING CAPTIVE SCREWS, SUGGESTED TORQUE: 5.0-6.0 IN LB, DO NOT OVER TORQUE.
- 4 TOLERANCES: .XX ± .03
.XXX ± .010

REFERENCE INSTALLATION DRAWING: AT5756855.

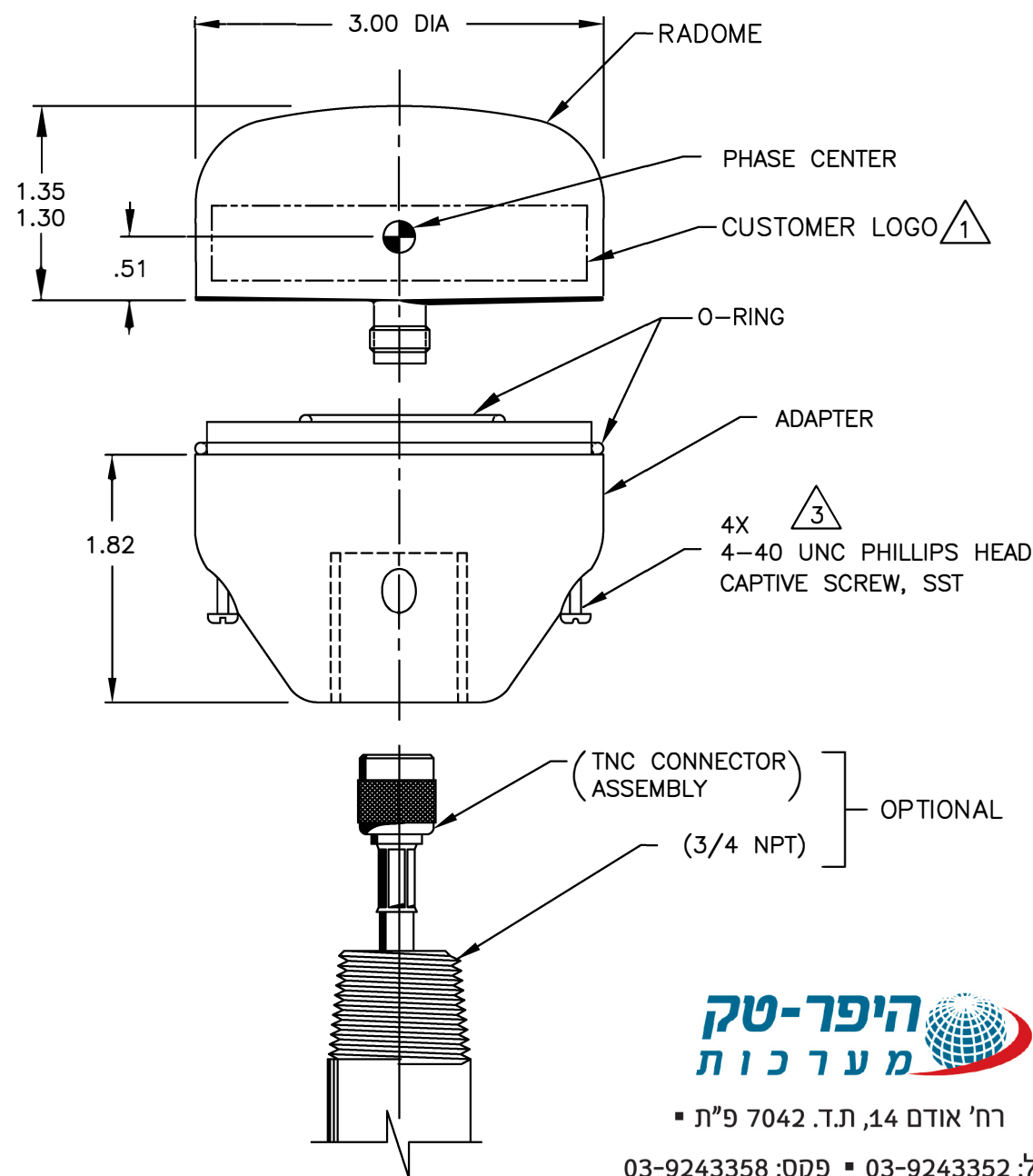

SPECIFICATION:

FREQUENCY: 1575 ±2 MHz
 POLARIZATION: RIGHT HAND CIRCULAR
 AXIAL RATIO: 1.5 dB MAX
 RADIATION COVERAGE: 4.0 dBic 0° = 0°
 -3.0 dBic 0° < θ < 75°
 -7.5 dBic 75° ≤ θ < 80°
 -8.0 dBic 80° ≤ θ < 85°
 -9.0 dBic 85° ≤ θ = 90°

AMPLIFIER: <1.5:1
 NOISE FIGURE: 2.5 dB MAX
 IMPEDANCE: 50 OHMS
 VSWR: ≤2.0 : 1
 BAND REJECTION: 30 dB @ 1535 MHz (f_o -40 MHz)
 60 dB @ 1615 MHz (f_o +40 MHz)
 POWER HANDLING: 1 WATT (INCLUDING IN-BAND)

FINISH: WEATHERABLE POLYMER
 WEIGHT: 8 OZ MAX
 ALTITUDE: 55,000'
 OPERATING TEMP: -55°C TO +85°C
 DESIGNED TO: D0-160C

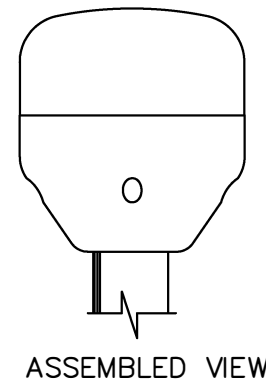

PART NO. DESIGNATION:

AT575-146X-XXXX-XXX-XX-XX-XX

COLOR
 W = WHITE
 S = SMOKE GRAY
 O = OLIVE DRAB

CONNECTOR
 * TNCM = TNC MALE
 TNCF = TNC FEMALE
 * BNCM = BNC MALE
 BNCF = BNC FEMALE
 * MCXM = MCX MALE
 * MCXF = MCX FEMALE
 * SMAM = SMA MALE
 * SMAF = SMA FEMALE
 * NTPM = N TYPE MALE
 * NTPF = N TYPE FEMALE
 * 0000 = NO TERMINATION

CABLE LENGTH
 * 000 = IN INCHES

MAGNET
 NM = NO MAGNET
 * IM = INTERNAL
 * RM = REMOVABLE
 * HD = HEAVY DUTY

GAIN (±2 dB)
 00 = PASSIVE
 14 = 14 dB (20 mA)
 26 = 26 dB (35 mA)
 40 = 40 dB (50 mA)
 XX = OTHER

VOLTAGE
 00 = PASSIVE
 05 = 5 VDC
 * RG = 5-18 VDC
 XX = OTHER

* = OPTION NOT AVAILABLE WITH THIS MODEL
 STANDARD MODEL = AT575-146W-TNCF-000-05-26-NM



ח' אודם 14, ת.ד. 7042 פ"ת

טל: 03-9243352 ▪ פקס: 03-9243358

www.hypertech.co.il ▪ sales@hypertech.co.il

DO NOT SCALE THIS DRAWING	DRAWN A. DEVERA	08/21/00	AeroAntenna Technology Inc	
ALL DIMENSIONS ARE IN INCHES DIMENSIONING & TOLERANCING PER ANSI Y14.5M-1982	CHECKED			
TOLERANCES: .XX = ±.01 .XXX = ±.005 FRACT = ±1/32 ANG. = ±1/2°	ENGR T. JEENSALUTE	08/22/00	TITLE GPS ANTENNA	
✓ SURFACE ROUGHNESS PER ANSI B46.1 REMOVE BURRS AND BREAK SHARP EDGES: PART TO BE CLEAN AND OIL FREE	Q.A. B. RUBENI	08/25/00	SIZE B	CAGE CODE OUVG2
USED ON	APPROVED G. SHACHAR	08/28/00	DRAWING NO. AT575-146	REV A
UNLESS OTHERWISE SPECIFIED	DRAWN IN ACAD	SCALE NONE	AT575-146A	SHEET 1 OF 1