

REVISIONS			
SYM	DESCRIPTION	DATE	APPROVED
J	UPDATE PER ECO 9422	09/27/10	
REMOVE LOCKING SCREW			

NOTES: UNLESS OTHERWISE SPECIFIED.

- 1 O-RING AND MOUNTING SCREWS SUPPLIED BY AEROANTENNA.
- 2 LABEL SIZE, SHAPE, CONTENTS AND LOCATION ARE SUBJECT TO CHANGE WITHOUT NOTICE.
- 3. TOLERANCE: .XX = ±.03
.XXX = ±.010

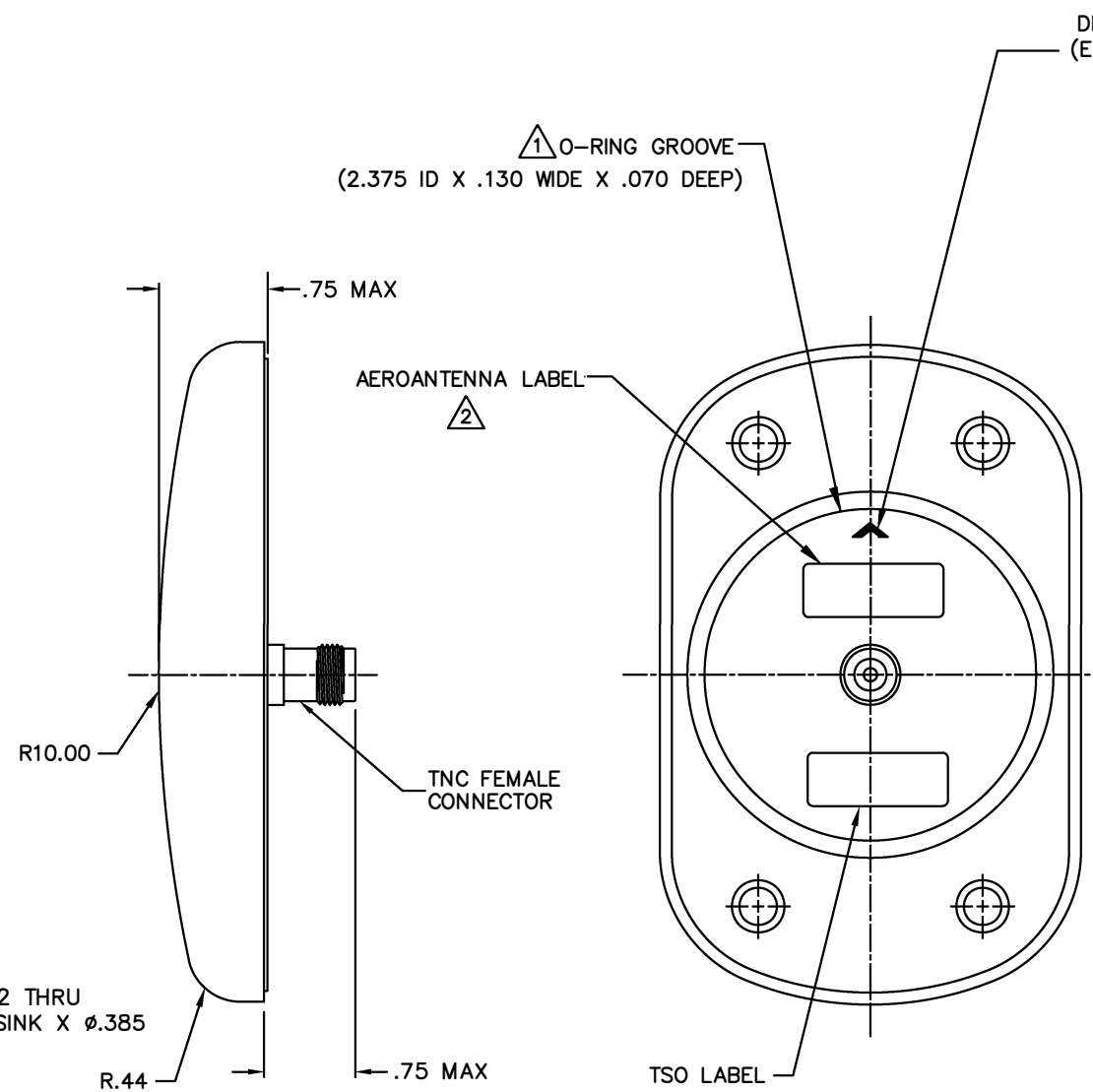
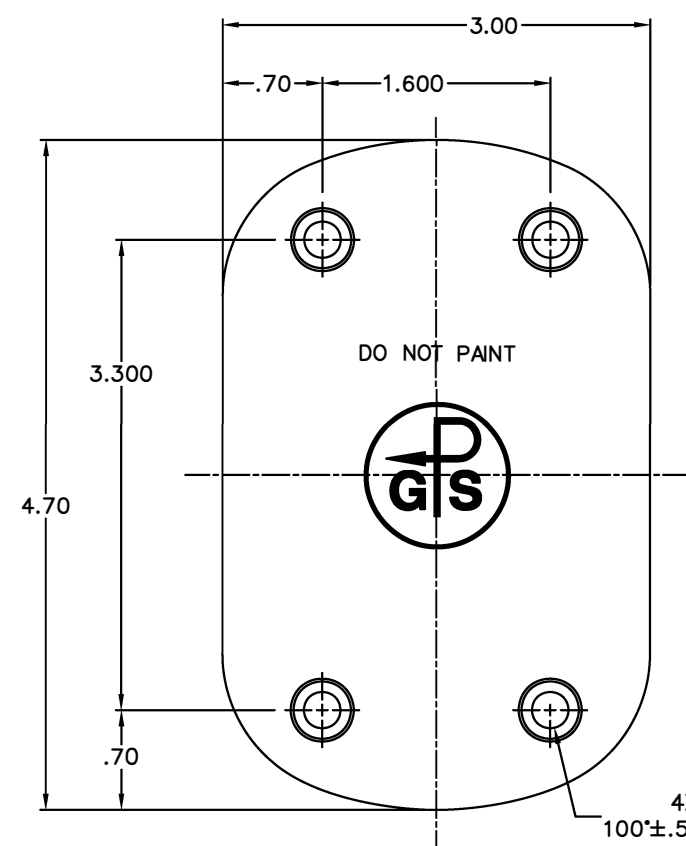

SPECIFICATION:

FREQUENCY: 1575 ±10 MHz
 POLARIZATION: RIGHT HAND CIRCULAR
 AXIAL RATIO: 3 dB MAX. AT BORE SIGHT
 RADIATION COVERAGE: ELEVATION ANGLE MINIMUM GAIN
 > 15° -2.0 dBic
 10° -3.0 dBic
 5° -4.5 dBic
 0° -7.5 dBic

AMPLIFIER: SPECIFY
 GAIN: 3.2 dB MAX. @25°C
 NOISE FIGURE: 50 OHMS
 IMPEDANCE: ≤2.0:1
 VSWR: EXCEEDS RTCA/DO-228 CHANGE 1
 BAND REJECTION: 1 WATT
 POWER HANDLING: POLYURETHANE
 FINISH: 8 OZ MAX.
 WEIGHT: 55,000'
 ALTITUDE: -70°C TO +70°C
 OPERATING TEMP: DO-160D
 DESIGNED TO: ENV CAT: F2-ABD[S(CLMY)U(FF1)]ESFDFSB[BZ]AZZ[YYP]H[A4ZZ][2A]CA
 MIL-STD-810C
 ARINC 743, RTCA/DO-208,228
 MIL-STD-810C
 C144
 C144



PART NO. DESIGNATION:

AT575-143XXX-XXXX-XXX-XX-XX-XX

CUSTOMER ID (IF APPLICABLE)
 COLOR: W = WHITE, S = SMOKE GRAY
 CONNECTOR: TNC F = TNC FEMALE
 CABLE LENGTH: 000 = IN INCHES

MAGNET: NM = NO MAGNET
 GAIN (±3 dB): 29.5 = 29.5 dB (50 mA max), 26 = 26 dB (50 mA max)
 VOLTAGE: RG = 5 - 18 VDC



03-9243358 :פסק 03-9243352 :טל 7042 9"פ"ת 14 אודם ת.ד. 03-9243358 :פסק
 www.hypertech.co.il • sales@hypertech.co.il

STANDARD MODEL= AT575-143W-TNCF-000-RG-29.5-NM

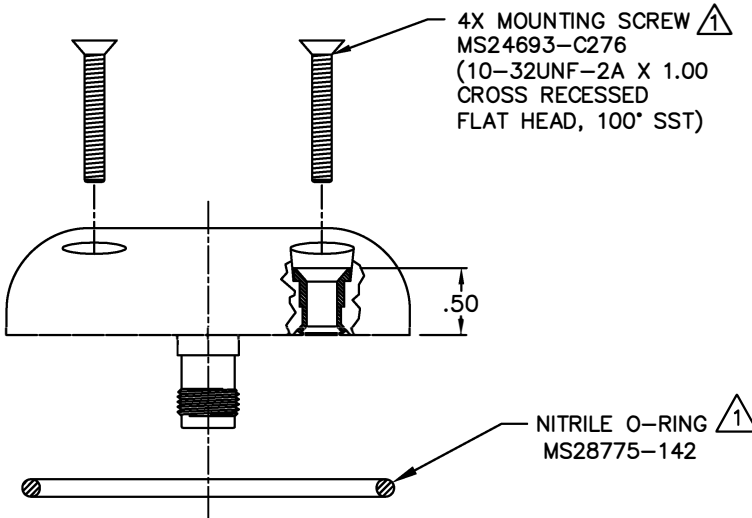

DO NOT SCALE THIS DRAWING	DRAWN	A. DEVERA	03/31/99
REMOVE BURRS AND BREAK SHARP EDGES:	CHECKED	J. BAELLY	08/06/99
PART TO BE CLEAN AND OIL FREE	ENGR	T. JEENSALUTE	08/05/99
ALL DIMENSIONS ARE IN INCHES DIMENSIONING & TOLERANCING PER ASME Y14.5M-1994	MFG	D. LEVY	01/27/04
TOLERANCES:	Q.A.	B. RUBENI	08/05/99
→XX ±.01 FRACT = ±1/32	APPROVED	G. SHAR	08/05/99
→XXX ±.005 ANG. = ±1/2°	DRAWN IN	CAD	
✓ SURFACE ROUGHNESS MACHINED PARTS V63 MOLDED PARTS V32			
HOLE DIA. TOLERANCE			
.0135 - .125 +.001/-0.001			
.126 - .250 +.005/-0.001			
.251 - .500 +.008/-0.001			
.501 - .750 +.008/-0.001			

AeroAntenna Technology Inc
 AS9100 CERTIFIED CO.

TITLE: GPS ANTENNA

SIZE: B CAGE CODE: OUVG2 DRAWING NO.: AT575-143 REV: J

SCALE: NONE I:\CAD\AT575\143\AT575-143_J SHEET 1 OF 1

PROPRIETARY NOTE: This document contains information of AeroAntenna Technology Inc. (AAT). Neither the document nor said proprietary information shall be published, reproduced, copied, disclosed or used for any other purpose other than consideration of document without the express written permission of a duly authorized representative of said AeroAntenna Technology Inc.