

Velodyne LiDAR[®] ULTRA Puck[™]

HIGH DEFINITION REAL-TIME 3D LiDAR
FOR AUTONOMOUS SYSTEMS



VLP-32C



Automotive



Robotics



Mapping



UAV



Security



Industrial

Velodyne LiDAR's ULTRA Puck VLP-32C is an advanced sensor that combines long-range performance with 0.33 degree vertical resolution in a compact form factor. It is a high-resolution sensor developed with automotive applications in mind and it retains the innovative breakthroughs in 3D LiDAR, such as 360° surround view with real-time 3D data. The VLP-32C includes distance and calibrated reflectivity measurements at all rotational angles.

Wide Field of View with Enhanced Point Density and Range

With 32 channels and a range of up to 200 m, the VLP-32C generates approximately 1,200,000 points/second in dual return mode, with a 360° horizontal field of view and a 40° vertical field of view. The ULTRA Puck's denser channel distribution on the horizon enables higher resolution at longer ranges. Operating it in dual return mode allows the capture of greater detail with 3D imagery. A compact footprint and low weight make the sensor ideal for automotive applications. It is also encapsulated in a package that allows for operation over a range of environmental conditions.



DIMENSIONS *(Subject to change)*

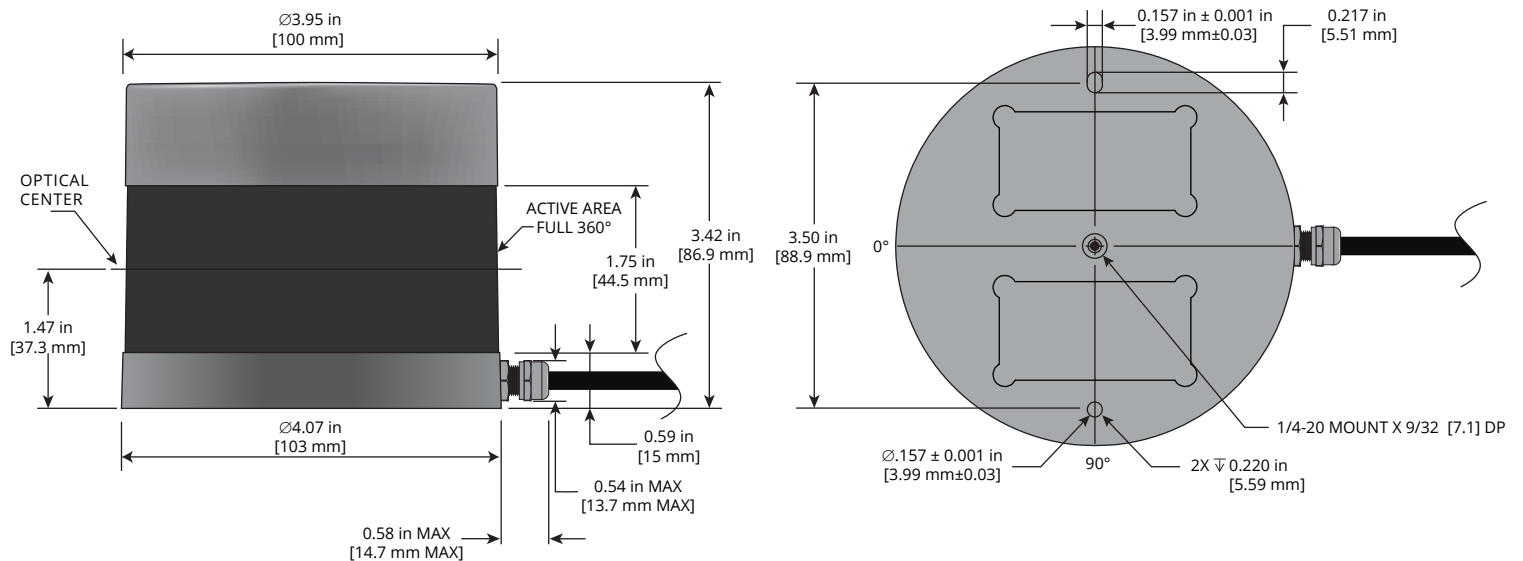

Real-Time 3D LiDAR Sensor

The ULTRA Puck™ provides high definition 3-dimensional information about the surrounding environment.



ULTRA Puck™

Specifications

(Subject to change)

Sensor	<ul style="list-style-type: none"> • Channels: 32 • Measurement Range: 200 m • Range Accuracy: Up to ± 3 cm (Typical)¹ • Horizontal Field of View: 360° • Vertical Field of View: 40° (-25° to +15°) • Minimum Angular Resolution (Vertical): 0.33° (non-linear distribution) • Angular Resolution (Horizontal/Azimuth): 0.1° to 0.4° • Rotation Rate: 5 Hz to 20 Hz • Integrated Web Server for Easy Monitoring and Configuration
Laser	<ul style="list-style-type: none"> • Laser Product Classification: Class 1 – Eye-safe per IEC60825-1:2014 • Wavelength: ~903 nm
Mechanical/ Electrical/ Operational	<ul style="list-style-type: none"> • Power Consumption: 10 W (Typical)² • Operating Voltage: 10.5 V – 18 V (with interface box and regulated power supply) • Weight: ~925 g (typical, without cabling and interface box) • Dimensions: See diagram on previous page • Environmental Protection: IP67 • Operating Temperature: -20°C to +60°C³ • Storage Temperature: -40°C to +85°C
Output	<ul style="list-style-type: none"> • 3D LiDAR Data Points Generated: <ul style="list-style-type: none"> - Single Return Mode: ~600,000 points per second - Dual Return Mode: ~1,200,000 points per second • 100 Mbps Ethernet Connection • UDP Packets Contain: <ul style="list-style-type: none"> - Time of Flight Distance Measurement - Calibrated Reflectivity Measurement - Rotation Angles - Synchronized Time Stamps (μs resolution) • GPS: \$GPRMC and \$GPGGA NMEA Sentences from GPS Receiver (GPS not included)

63-9378 Rev-D

1. Typical accuracy refers to ambient wall test performance across most channels and may vary based on factors including but not limited to range, temperature and target reflectivity.

2. Operating power may be affected by factors including but not limited to range, reflectivity and environmental conditions.

3. Operating temperature may be affected by factors including but not limited to air flow and sun load.